

THE ICONIC **FORD** **FALCON XB GT**

SCALE
1:8



Floor Panel



Cars on Screen

Published weekly
UK: £10.99 AUS: \$21.99



POST-APOCALYPTIC EDITION

THE ICONIC FORD FALCON XB GT

ISSUE 25

ASSEMBLY GUIDE

3

A panel is fitted to the chassis assembly put together in the previous issues.

CARS ON SCREEN

7

Goldfinger, the third James Bond movie, featured an Aston Martin DB5 — a car later dubbed 'The Most Famous Car in the World'.

YOUR MODEL

You will be building a 1:8 scale replica of a customised 1973 Ford Falcon XB GT. Features include a lift-up bonnet that reveals a detailed engine, opening doors, wind-down windows and an 'active' steering wheel. A remote-control fob illuminates the main lights, brake lights and indicators.

Scale: 1:8
Length: 62cm
Width: 25cm
Height: 19cm
Weight: 7+kg



Ford Motor Company
trademarks and trade dress
used under licence to GRE
for Groupe ELIGOR

CUSTOMER SERVICE, SUBSCRIPTIONS & BACK ORDERS

Please visit hachettepartworks.com/contact to get in touch.

Published by Hachette Partworks Ltd
4th Floor, Jordan House, 47 Brunswick Place,
London, N1 6EB
www.hachettepartworks.com



© 2025 Hachette Partworks Ltd
© 2025 Ford Motor Company
Distributed in the UK and Republic of Ireland by Marketforce.
Printed in the United Kingdom
ISSN 2976-5811

Complete in 130 issues.

ALL RIGHTS RESERVED

Items may vary from those shown.
All parts belong to a kit. Collectors' item for adults. Not suitable for children under 14. Some parts may have sharp edges, please handle them with care.

The installation of electronic parts must always be carried out by an adult. When replacing batteries, use the same type of batteries. Please ensure that the battery compartment is securely fastened before you use the model again. Used batteries should be recycled. Please make sure to check with your local council how batteries should be disposed of in your area. Batteries can present a choking danger to small children and may cause serious harm if ingested. Do not leave them lying around and keep any spare batteries locked away at all times.

The editor's policy is to use papers that are natural, renewable and recyclable products and made from wood grown in sustainable forests. The logging and manufacturing processes are expected to conform to the environmental regulations of the country of origin.

In the event of a significant increase in production and transport costs, the publisher reserves the right to modify its selling prices.

MANAGING DIRECTOR – Isabelle Couderc
EDITORIAL DIRECTOR – Helen Nally
MARKETING DIRECTOR – Elise Windmill
PRODUCTION DIRECTOR – Sema Sant Anna
SENIOR PRODUCTION MANAGER – Lee Matthews
MANAGING EDITOR – Sarah Gale
PROJECT EDITOR – Gary Webb
DISTRIBUTION MANAGER – Paul Smith
PRODUCT MANAGER – Rhys Myner

WHAT TO DO WITH YOUR PACKAGING?

Our packaging papers and boxes are 100% recyclable kerbside. Plastic blisters can also be 100% recyclable kerbside once separated from the cardboard. To find out what you can recycle at home and locally, please visit www.recyclenow.com



For our environmental policy in full please scan the QR code here



NOT SUITABLE FOR CHILDREN UNDER THE AGE OF 14.
This product is not a toy and is not intended for use in play.

Editorial and design: Windmill Books Ltd

Picture credits: Front Cover: Jess Esposito and David Burton: main; Richard Bryden: bl; Chiltegreen bc; Shutterstock: Steven Giles background.

Interior: Alamy: Ian Bottle p7.

Step-by-step photography: Richard Bryden

Model photography: Jess Esposito and David Burton

Windmill Books have made every attempt to contact the copyright holder, if you have any information please contact Sophie Mortimer: smortimer@windmillbooks.co.uk

t=top, c=centre, b=bottom, l=left, r=right, u=upper



Stage 25: Floor Panel

A panel is fitted to the chassis assembly from the previous issues.

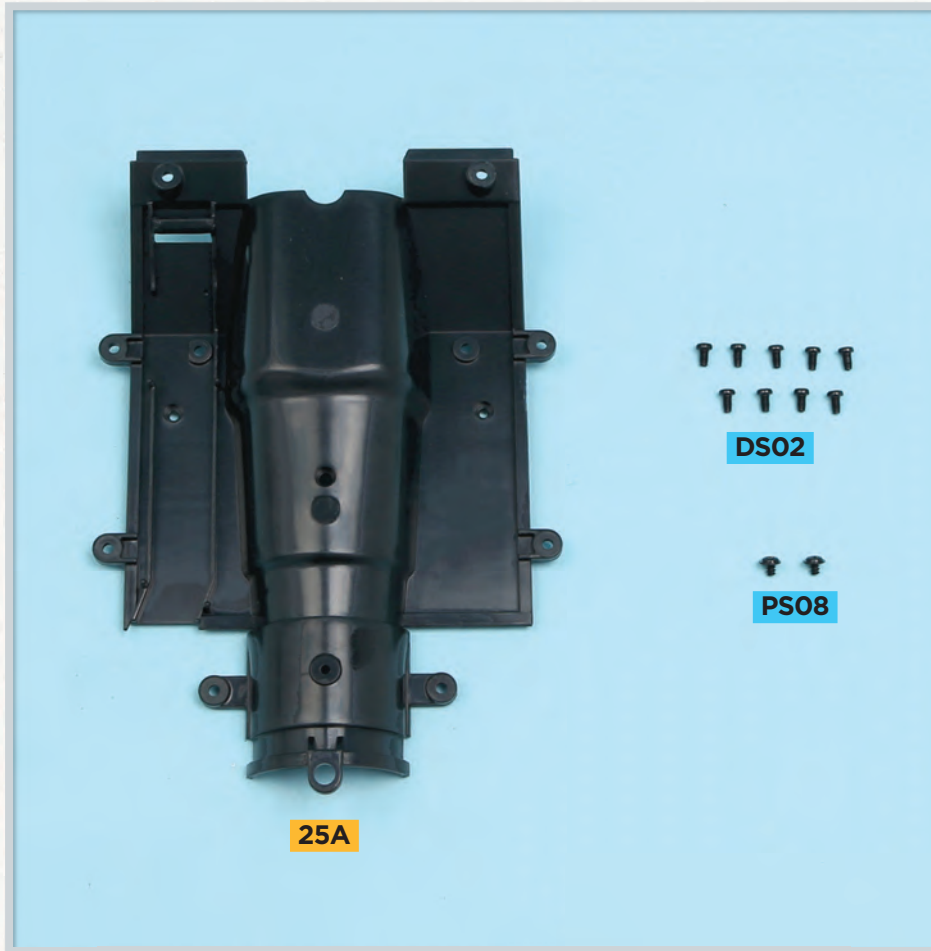

List of parts:

- 25A** Floor panel
- DS02** Nine* 2.3 x 4mm PM screws
- PS08** Two* 2.3 x 3mm PB screws

* Including spare

PM = Pan head for metal

PB = Pan head for plastic

Area of assembly

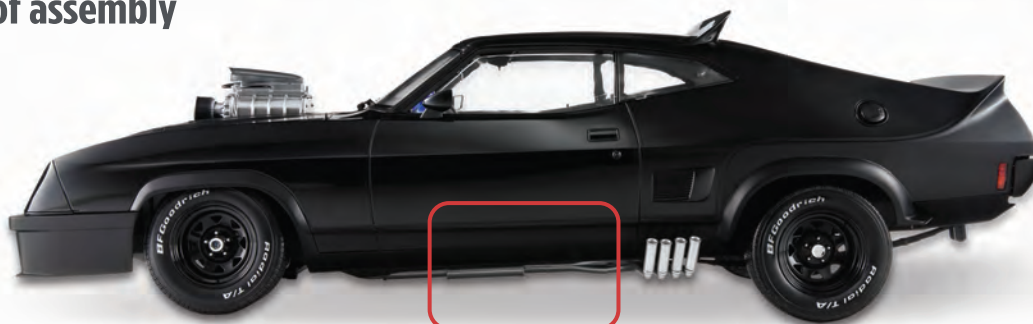

Stage 25: Floor Panel



STEP 1

Take the chassis assembly from the previous issue and part **25A**. Fit part **25A** over the open part of **24A** so that the rear end of the transmission tunnel on part **25A** fits over the transmission tunnel on part **23A**.

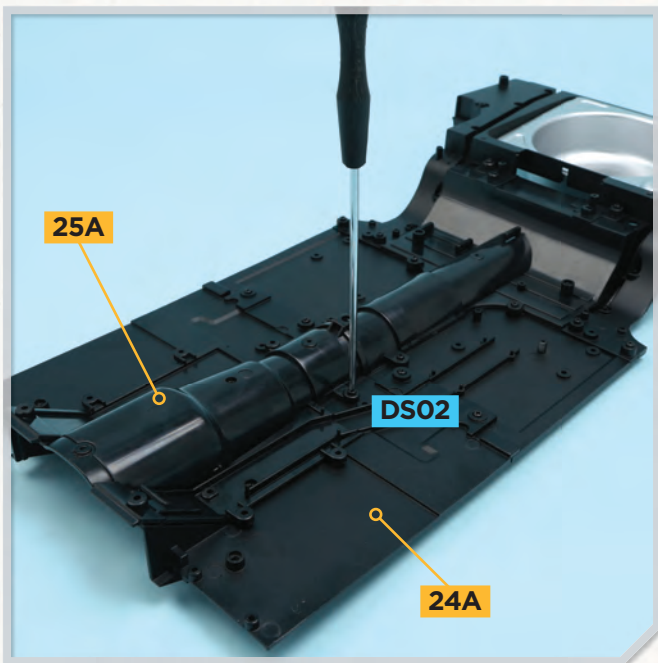

STEP 2

At one end of part **25A** is a tab with a screw hole, which is aligned with a socket in the chassis frame **24A**. Fix in place with a **DS02** screw.

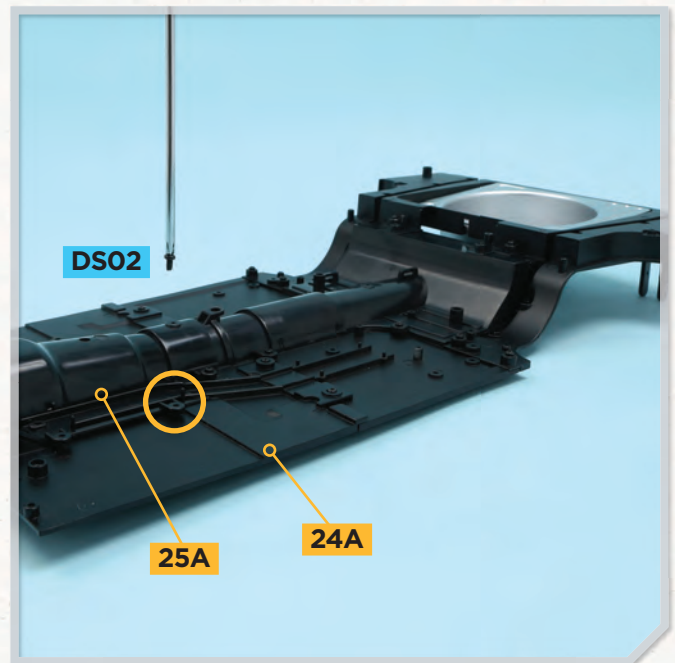

STEP 3

The next fixing point is a tab on the side of part **25A** (circled). Fix in place with a **DS02** screw.

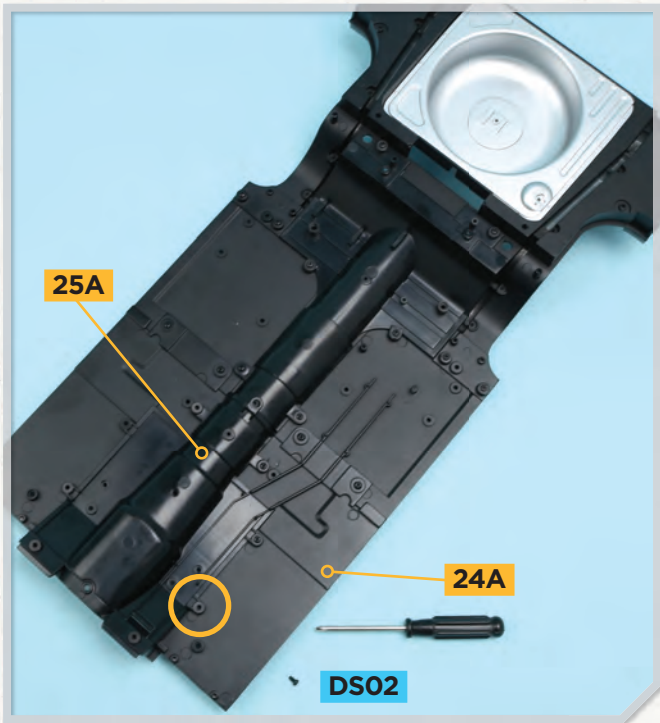

STEP 4

A third **DS02** screw is fitted further along the side of part **25A** (circled).



STEP 5

The last fixing point on the left side of the chassis assembly is on the raised ends of parts **24A** and **25A**. Fix in place with another **DS02** screw.

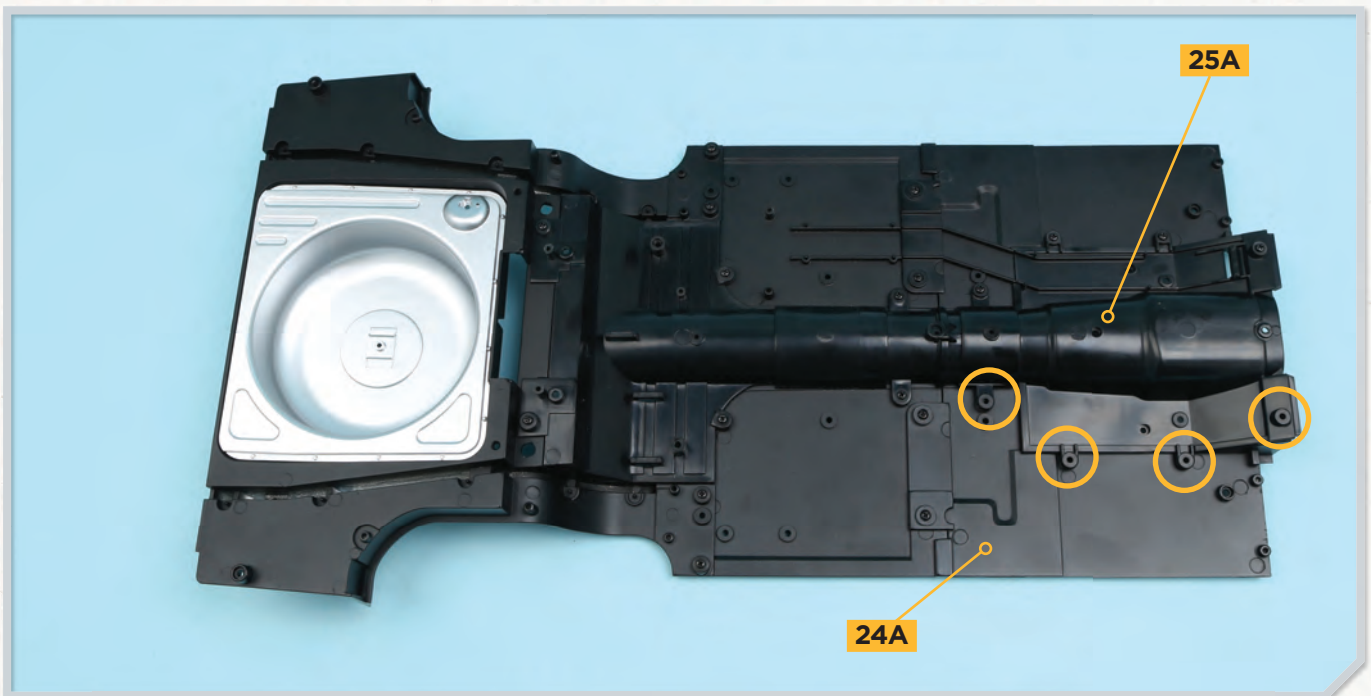

STEP 6

Turn the assembly round so that you can fit four more **DS02** screws. The four screw holes are circled.

Stage 25: Floor Panel

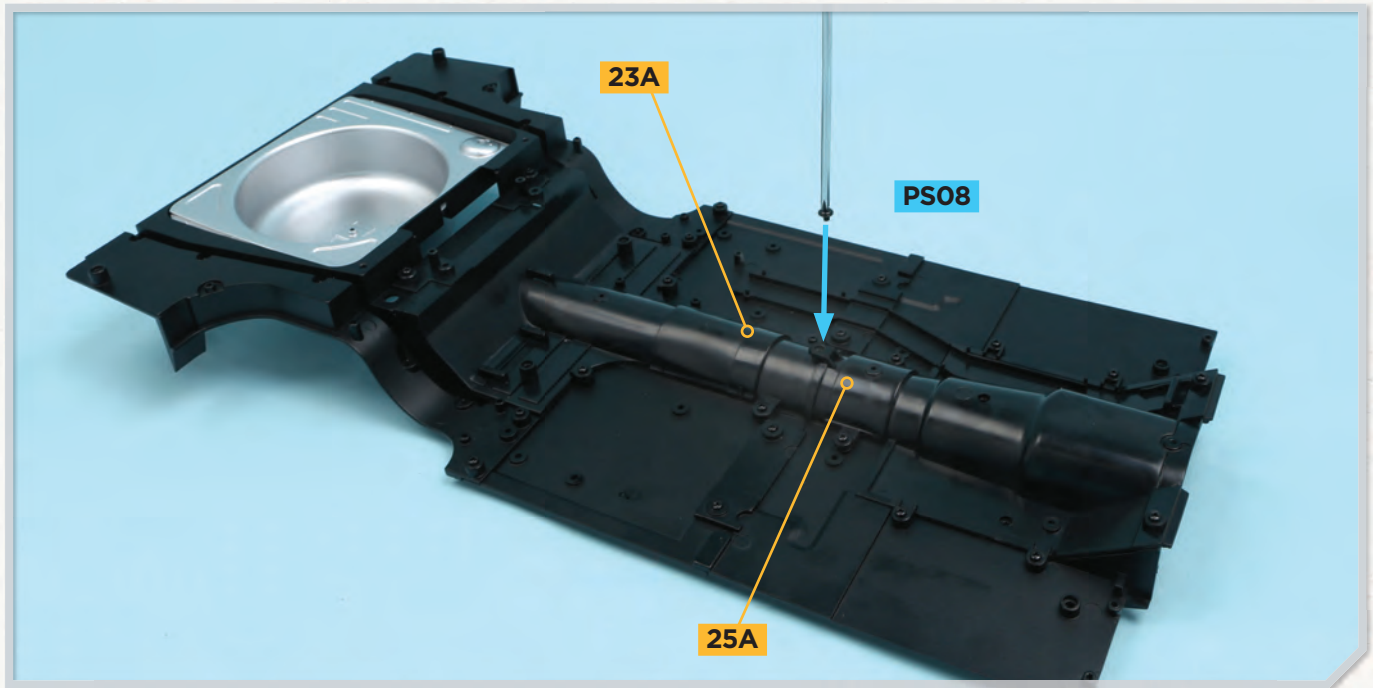

STEP 7

A tab with a screw hole on top of the transmission tunnel on part **25A** aligns with a screw socket in part **23A**. Fix the parts together with a **PS08** screw.

COMPLETED ASSEMBLY

A floor panel has been fitted to the chassis.

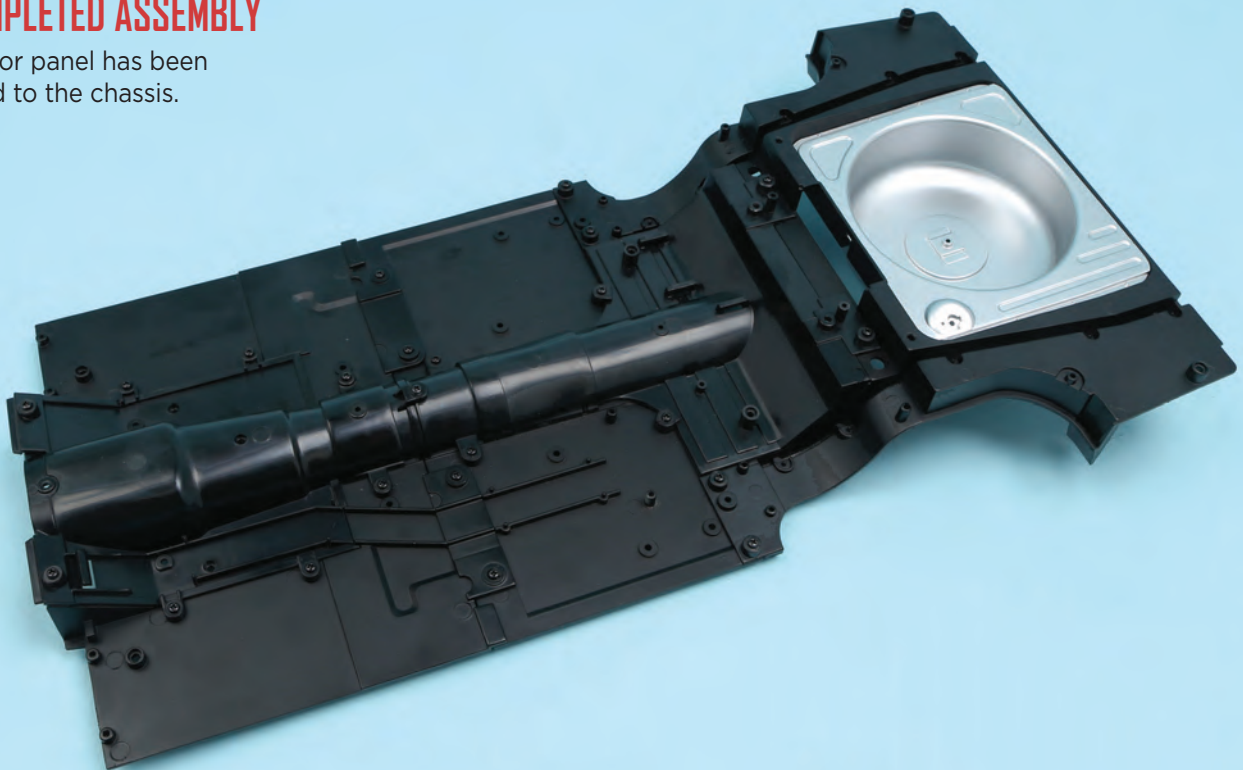

Goldfinger (1964)

The third James Bond movie featured an Aston Martin DB5 — but not all the new American vehicles used in the film had a happy ending.

Goldfinger, the first of four Bond films directed by Guy Hamilton, was the initial Bond blockbuster. Its budget exceeded the two previous titles combined. The plot has Bond (Sean Connery) investigating the gold smuggling business of Auric Goldfinger (Gert Fröbe). Bond uncovers a plot to contaminate the US Fort Knox Bullion Depository. Based on the 1959 novel by Ian Fleming, the book had Bond driving an Aston Martin DB III. On screen Bond is issued an 'Aston Martin DB5 with modifications.'

The DB5 was Aston's latest model, but initially the company was reluctant to supply one. The car used was the prototype DB5 repainted from its original red into Silver Birch. Film crew members suggested possible gadgets. The revolving license plate came from Hamilton, who had received multiple parking tickets, his son suggested a passenger ejector seat. Taillights that dropped sharp nails were replaced with an oil slick to avoid viewers replicating it. The glass was bulletproof (in the script anyway) and there was also a bulletproof shield rising up from the bootlid to protect the rear window. Adam and engineer John Stears built the features into the 'stunt' DB5 in six weeks. Tyre-destroying spikes couldn't be made functional so were done in studio, while the ejector seat was powered by external compressed air, with a dummy in the seat. After filming, the stunt car was returned



to standard (around 1968) and sold on. Re-registered it later appeared in *The Cannonball Run* (1981), then was stolen from a hangar in Florida and never recovered.

A second Aston without any gadgets was created for driving scenes in Switzerland. This second car was fitted with similar gadgets and used for publicity purposes. It appeared in *Thunderball* (1965) and sold at auction in 2010. Two further Astons were fitted with gadgets in 1964 and sent on world tours, both are now in museums.

FORD PUBLICITY

The Ford Motor Company was keen to get publicity for their new Mustang and supplied a white Mustang convertible. Ford had initially intended to supply a metalflake gold Mustang fastback but the car wasn't ready until mid-October 1964 and filming finished in August. Ford did, however, get several products onto screen,

Recreation of the 1964 James Bond Aston Martin DB5 photographed at Hampton Court Palace in 2023.

including an eight-passenger 1964 (Galaxie) Country Squire station wagon used to transport Bond from the airport to Goldfinger's stud farm in Kentucky. A 1964 Lincoln Continental was used for the 'murder' of mafia man Solo, although it was actually a 1963 Continental without an engine that went into the car crusher in an effort to keep costs down. Its squashed wreck had to be partially cut up after the 1964 Ford Falcon Ranchero pickup it was dropped into suffered collapsed suspension from overloading it with the two-ton weight. Several American vehicles had to be imported into the UK. Since no duties were paid on them, it is understood that a brand new 1964 Thunderbird and the 1964 Continental were destroyed in the UK. ■

COMING IN ISSUE 26



• ASSEMBLY GUIDE

A frame to support the engine is fitted to the front of the chassis assembly.

• DESIGNS FOR A NEW ERA

Nicolas-Joseph Cugnot's 1769 steam-driven gun carriage was probably the world's first self-propelled vehicle, but it would be another century before the idea of a 'car' became a reality — Carl Benz patented his gasoline engine on 29 January 1886.

NEW PARTS

Chassis frame, chassis crosspiece and screws.

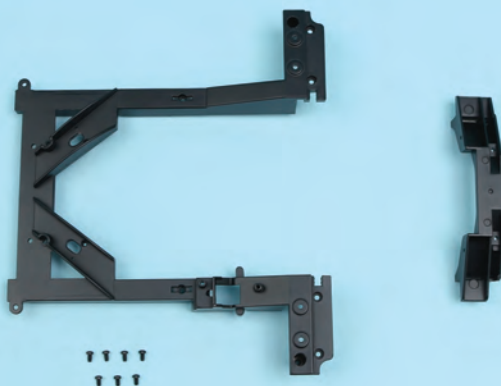

Published weekly

UK: £10.99

AUS: \$21.99



hachettepartworks.com/FordFalcon