

# THE DALEK

**BUILD  
THE ICONIC  
BBC**



**MONSTER**



**INSIDE THE  
EMPEROR DALEK!**



**STEP-BY-STEP  
INSTRUCTIONS!**

Published  
weekly • £11.99  
AUS • \$23.99

18



9 772977 557054

# DALEK

## ISSUE 18



### ADVENTURES IN TIME AND SPACE: THE PARTING OF THE WAYS

3

Can Rose use the power of the time vortex to defeat the Dalek threat?



### ANATOMY OF A DALEK: EMPEROR DALEK

6

Discover the truth about the ultimate ruler of the Daleks, the Emperor!



### STEP-BY-STEP BUILD: PART 1B

8

The video card, with the holding frame and back support!

## Reader Services

CUSTOMER SERVICE IN THE UK  
AND REPUBLIC OF IRELAND

### How to continue your collection:

Subscribe online at [hachettepartworks.com/Dalek](http://hachettepartworks.com/Dalek) or contact the Customer Service team via [hachettepartworks.com/contact](http://hachettepartworks.com/contact)

### Customer service & back orders:

Please visit [hachettepartworks.com/contact](http://hachettepartworks.com/contact) to get in touch.

UK call 0345 155 9277

ROI call (01) 9079762

(Calls are charged at your local rate from a landline)

Published by Hachette Partworks Ltd

4th Floor, Jordan House, 47 Brunswick Place, London N1 6EB

General Manager – Isabelle Couderc

Editorial Director – Helen Nally

Marketing Director – Elise Windmill

Production Director – Sema Sant Anna

Managing Editor – Sarah Gale

Distribution Manager – Paul Smith

Product Manager – Rhys Myner

Packaged by Panini Publishing, a division of Panini UK Limited.

Publishing Director Europe – Marco M. Lupoi

Managing Director – Chris Clover

Managing Editor – Alan O'Keefe

Senior Editor – Ed Hammond

Editor – John Ainsworth

Designer – Barry Spiers

Features Writer – Stuart Ashley

Distributed in the UK and Republic of Ireland by Marketforce.

© 2025 Hachette Partworks Ltd

Printed in the UK.

ISSN 2977-5574

ALL RIGHTS RESERVED

The editor's policy is to use papers that are natural, renewable and recyclable products and made from wood grown in sustainable forests. The logging and manufacturing processes are expected to conform to the environmental regulations of the country of origin.

In the event of a significant increase in production and transport costs, the publisher reserves the right to modify its selling prices.

BBC, DOCTOR WHO, TARDIS and DALEK (word marks and devices) are trade marks of the British Broadcasting Corporation and are used under licence. BBC logo © BBC 1996. DOCTOR WHO logo © BBC 1973. Dalek image © BBC/Terry Nation 1963. Licensed by BBC Studios.

The device complies with Part 15 of the FCC Rules. Operation is subject to the following two conditions: (1) this device may not cause harmful interference, and (2) this device must accept any interference received, including interference that may cause undesired operation.

All parts belong to a kit. NOT SUITABLE FOR CHILDREN UNDER THE AGE OF 14. This product is not a toy and is not intended for use in play. Follow the instructions in the enclosed magazines carefully and keep the appropriate information in a safe place. The installation of the electrical and electronic parts must always be carried out by an adult. Requires batteries.

BBC



For our environmental policy in full please scan the QR code here.

 **hachette**  
PARTWORKS LTD

### WHAT TO DO WITH YOUR PACKAGING?

Our packaging papers and boxes are 100% recyclable kerbside. Plastic blisters can also be 100% recyclable kerbside once separated from the cardboard. To find out what you can recycle at home and locally, please visit [www.recyclenow.com](http://www.recyclenow.com)



# THE PARTING OF THE WAYS

The Doctor, Rose and Jack find themselves contestants in deadly TV game shows.

Series 1 Episode 13  
First Broadcast: 18 June 2005

**T**rapped on the Dalek mothership, Rose Tyler watches as the Daleks prepare for combat. One of them turns to her. "You know the Doctor!" it declares. "You understand him! You will predict his actions!" Rose refuses to help the creature. The TARDIS is detected. It is hurtling towards the massive Dalek spacecraft. Two missiles are launched...



Inside the TARDIS, the Doctor and Jack Harkness are hastily operating the controls of the console. "We've got incoming!" Jack yells. The missiles collide with the TARDIS in space and explode. But the TARDIS is protected by an invisible force field.

On the Dalek mothership, the Daleks watch as Rose and the Dalek nearest to her fade away, replaced by the materialising TARDIS...

Rose and the Dalek find themselves inside the TARDIS. Jack blasts the Dalek with the laser weapon taken from the Trine-E and Zu-Zana droids on the Game Station.

The Daleks surround the TARDIS, eager to attack. A massive voice reverberates across the command deck: "Patience, my brethren..."

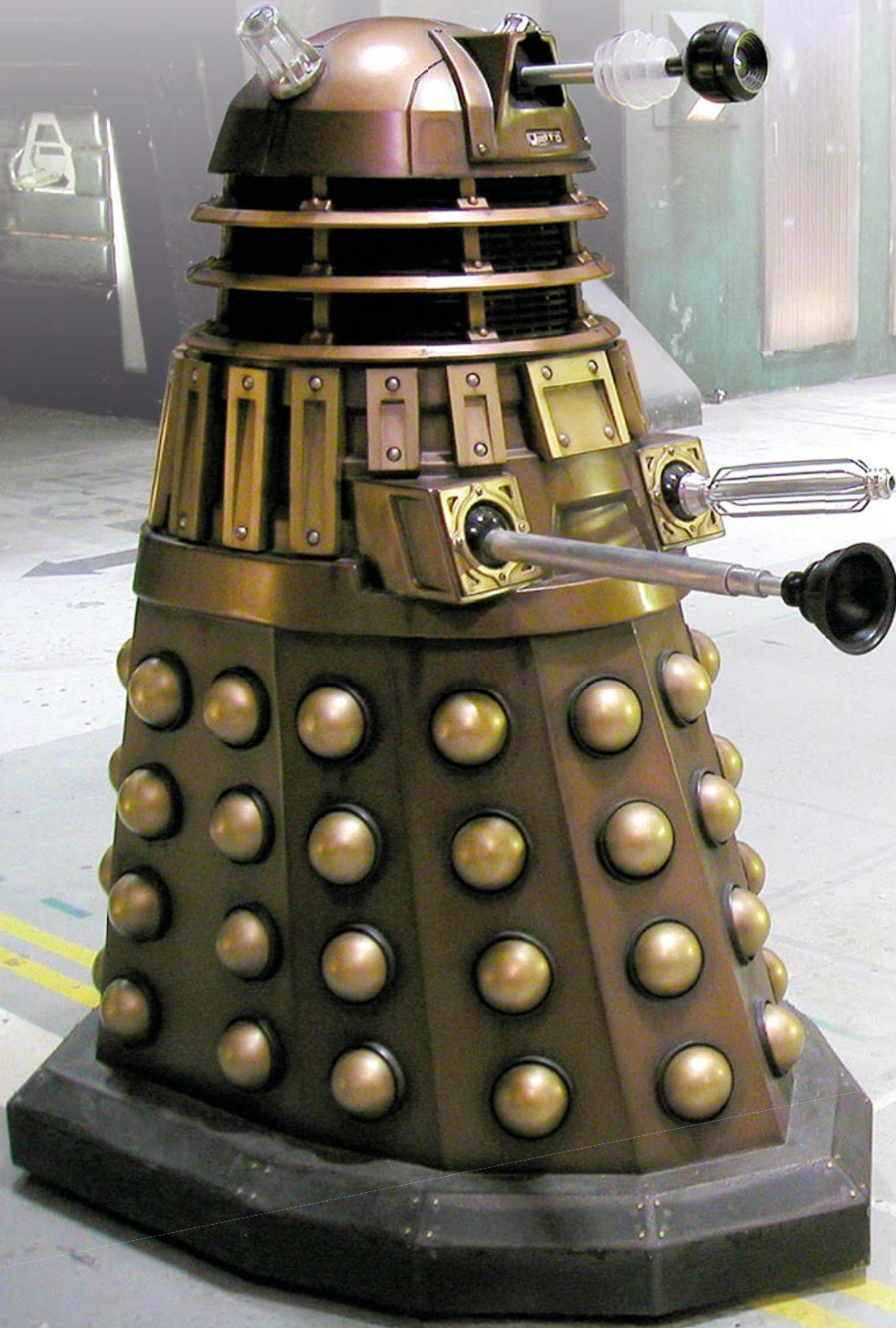

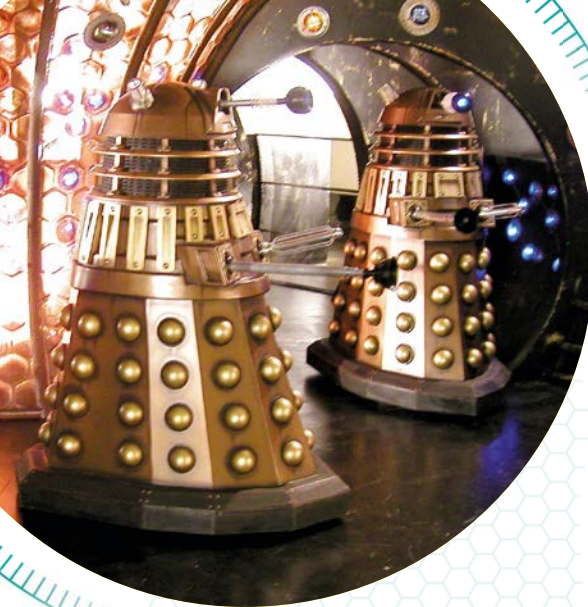

Rose stares at the remains of the Dalek mutant inside the TARDIS. "You said they were extinct, how come they're still alive?" she asks the Doctor. The Doctor explains that the Time Lords and the Daleks battled each other with all of existence at stake. "My people were destroyed but they took the Daleks with them." He stares at the Dalek. "Now it turns out they died for nothing."

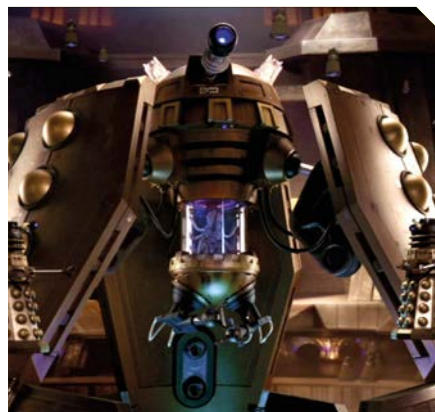

The Doctor steps out of the TARDIS. The Daleks immediately fire on him but their beams are stopped by his ship's force field. The Doctor wants to know how they survived the Time War. "They survived through me," answers the booming voice. The Doctor, Rose and Jack turn and walk towards a huge shape in the shadows. The Emperor of the Daleks is revealed. The Emperor explains that its ship was the sole survivor of the Time War. It fell through time. Centuries passed as the Daleks rebuilt themselves, infiltrating the systems of Earth. They have taken humanity's dead and turned them into Daleks. When Rose suggests that they are half-human, the Emperor is angered: "Those words are blasphemy!"

The Doctor, Rose and Jack return to the TARDIS and travel back to Floor 500 on the Game Station. The Doctor orders all transmitters to be turned up to full power to stop the Daleks from transmating on board. Earth has ignored the station's distress call. The Dalek fleet begins to head for Earth.

Jack realises that the Doctor is planning to create a weapon called a Delta Wave. Jack establishes a force field around the Game Station but the Daleks will still be able to enter it physically. They have to delay them long enough for the Doctor to complete the construction of the Delta Wave.

Rose assists the Doctor while the others prepare to repel the Daleks. Jack kisses Rose and the Doctor goodbye and heads for Floor 0, where around 100 people have been left stranded. He tries to



recruit them to help fight the Daleks, but only a few people join him. Rose and the Doctor work together, alone. The Delta Wave begins to grow in strength. The Doctor checks the readings to see how long it will need before it is ready. His head slumps. Then he looks up, elated. "Rose Tyler, you're a genius!" he cries. He says there is a way to use the TARDIS to cross his own timeline. He runs inside the TARDIS and starts flicking switches. He asks Rose to hold down a lever and runs back out onto Floor 500 again. The Doctor's expression suddenly changes to one of grim resignation. He aims his sonic screwdriver at his ship.

Inside, Rose is alarmed as the TARDIS engine rumbles into life. She tries to open the door. A flickering holographic image of the Doctor appears behind her. He tells her that she is being sent home to safety. He asks her to let the TARDIS be buried and forgotten. The hologram Doctor turns to look directly at Rose. "Have a good life," he says. The TARDIS lands. Rose runs outside to find the Powell Estate in London. Mickey Smith finds her. Rose hugs him, devastated.

## JACK'S JOURNEY

Jack Harkness sacrifices his life to stop the Daleks at the climax, demonstrating how much the Doctor's companion has changed since his introduction in *The Empty Child*. "The great thing about Jack's journey through these five episodes, and it culminates in episodes 12 and 13, is the fact that in the very beginning you meet him and he's this cheesy, arrogant, American piece of work," actor John Barrowman stated. "Chris [Eccleston] was saying one day to me, 'The Doctor's looking at Jack as if Jack doesn't have a soul, doesn't have a heart. Jack's just out to get what he wants.' Then as time goes on, he develops heart. And the relationship between Jack and the Doctor, and Jack and Rose, there is a love there." For their farewell scene, Barrowman said, "I kissed them basically with the same tenderness. It was a kiss of, 'I really, really care for you, I love you deeply and I have to say goodbye.'"



## DALEK INSIDER



Actor Barnaby Edwards had been the Dalek operator in that season's earlier story *Dalek*, and returned as the lead Dalek in *The Parting of the Ways*. "The thing I remember most about the barricade scene is that it was quite exciting to have that many people firing guns at you!" he recalled. "Obviously they were firing blank ammunition but the

sound of it was just as loud as the real thing. The armourer, Faujja Singh, was a guy who'd worked on the Bond movies. He was great. He was hilarious but when it came to work he was very serious, which of course he had to be. He really knew his stuff. These were real guns. Big, scary things. We had to wear ear protection inside the Daleks."

Jack contacts the Doctor and learns that he has sent Rose home. He asks the Doctor if the Delta Wave will be ready in time. A transmission from the Emperor Dalek interrupts them. It says that the Delta Wave can be completed but not in time for it to be refined. It will kill not only the Daleks but also all the humans on Earth. The Doctor knows this but is prepared to use it anyway. He asks the Emperor about the mysterious phrase he and Rose kept hearing on their travels: "Bad Wolf". The Emperor says he knows nothing of it.

Rose sits silently with her mother Jackie and Mickey in a diner. Rose is desperate to help the Doctor. She runs out of the diner. Mickey finds her in an empty playground. Rose sees the words "Bad Wolf" written in chalk on the ground. Rose wonders if the words could be a message for her. She decides to try to open the console and make contact with the heart of the TARDIS.

The Daleks invade the station. The humans' weapons prove useless against them. The Anne Droid disintegrates three Daleks before being destroyed. A Dalek squad exterminates the people hiding on Floor 0.



Mickey tries to open the console with a chain attached to his car, but fails. Jackie tells her to give up, but Rose refuses, and tells her of how the Doctor helped her meet her father in the past. Jackie runs off, upset.

Jack and the few people left prepare for the final assault. They are all exterminated.

Jackie returns to the TARDIS with a heavy recovery truck. They chain the console to it and, after a huge effort, open the console. Light streams out of it, into Rose's eyes. The TARDIS doors slam shut before Mickey can reach her. The ship fades away.

The Doctor has finished preparing the Delta Wave. Daleks glide in and surround him. The Emperor challenges him. "What are you: coward or killer?" The Doctor pauses with his hands on the switch. He removes them. "Coward," he answers. The Emperor says that mankind will be harvested, but the Doctor will simply be exterminated. The Doctor closes his eyes and waits for the end. But the TARDIS suddenly materialises behind him. Rose steps out, bathed in a golden aura. The Doctor is horrified when she tells him what she has done. "You've looked into the Time Vortex!" he cries. "Rose, no one's meant to see that!"

Rose has been transformed into the Bad Wolf. She takes the two words and scatters them across time to send herself the message. She dismisses the Emperor's claims of godhood. With a wave of her hand she divides every



atom holding the Emperor, the Daleks and the Dalek fleet together. They all dissolve into golden dust.

Rose brings Jack back to life. The Doctor begs her to stop; the power will consume her. She doesn't know how. The Doctor kisses her and draws the energy out of her and into his own body. Rose falls unconscious. The Doctor releases the energy back into the TARDIS.

Rose wakes up on the TARDIS floor, unable to remember what happened. The Doctor tries to be casual, but the Time Vortex energy has been too much for his body to withstand. He doubles up in pain and tells Rose that he is about to change. "Time Lords have this little trick. It's sort of a way of cheating death," he says. His body explodes into flame. Rose recoils, stunned. The flames subside and the Doctor she has known is gone, replaced by a different man entirely...

## MODEL EMPEROR

The model of the Emperor Dalek was constructed by a team led by model unit supervisor Mike Tucker. "Given that the Daleks themselves have been a physical prop, it makes sense that the Dalek Emperor is a physical prop as well," he said. "It is a new Dalek but at the same time, once you've got those studded panels, once you've got the domed head and the eye stalk, it instantly says 'Dalek'. And it's quite strange that you can't really do too much to those basic parameters without it still looking like Dalek technology, but then you start looking closer and you realise, 'Actually they've changed just about everything.' It's a very, very clever bit of redesign by Ed and his team."



Mike Tucker (bottom left) and his team who built the Emperor Dalek model.

# EMPEROR DALEK

There have been several Dalek Emperors throughout the species' history, but the one that led the Daleks during the Time War is easily the most formidable in appearance.

**T**he Emperor Dalek stands over 60-feet tall and speaks with a voice so great in volume that it shakes its surroundings. This effect is intentional; no Emperor before it has ever had such a keen desire to impose total awe upon its subjects. The Emperor's mutant form is on display for all to see in a transparent tank beneath its upper dome [1]. This is an unprecedented sight in Dalek culture. Daleks have always kept their mutated bodies hidden inside their casings at all times. They have an instinctive desire to always wear their armour, not only for protection but as part of a constant need to display their strength. They are well aware of the vulnerability of their natural forms, even if they cannot admit this to other life forms or even each other. For the Emperor to choose to expose itself in this way marks it as a true individual in Dalek society. This is in one sense a dangerous move; total conformity is the rock-solid foundation of the Dalek ethos. A Dalek who separates itself from the masses is usually perceived as an abomination and exterminated. However, the Emperor is the one exception to this rule. While it can never take a name, the Emperor is still allowed to act and think as an individual and grant itself a unique appearance.

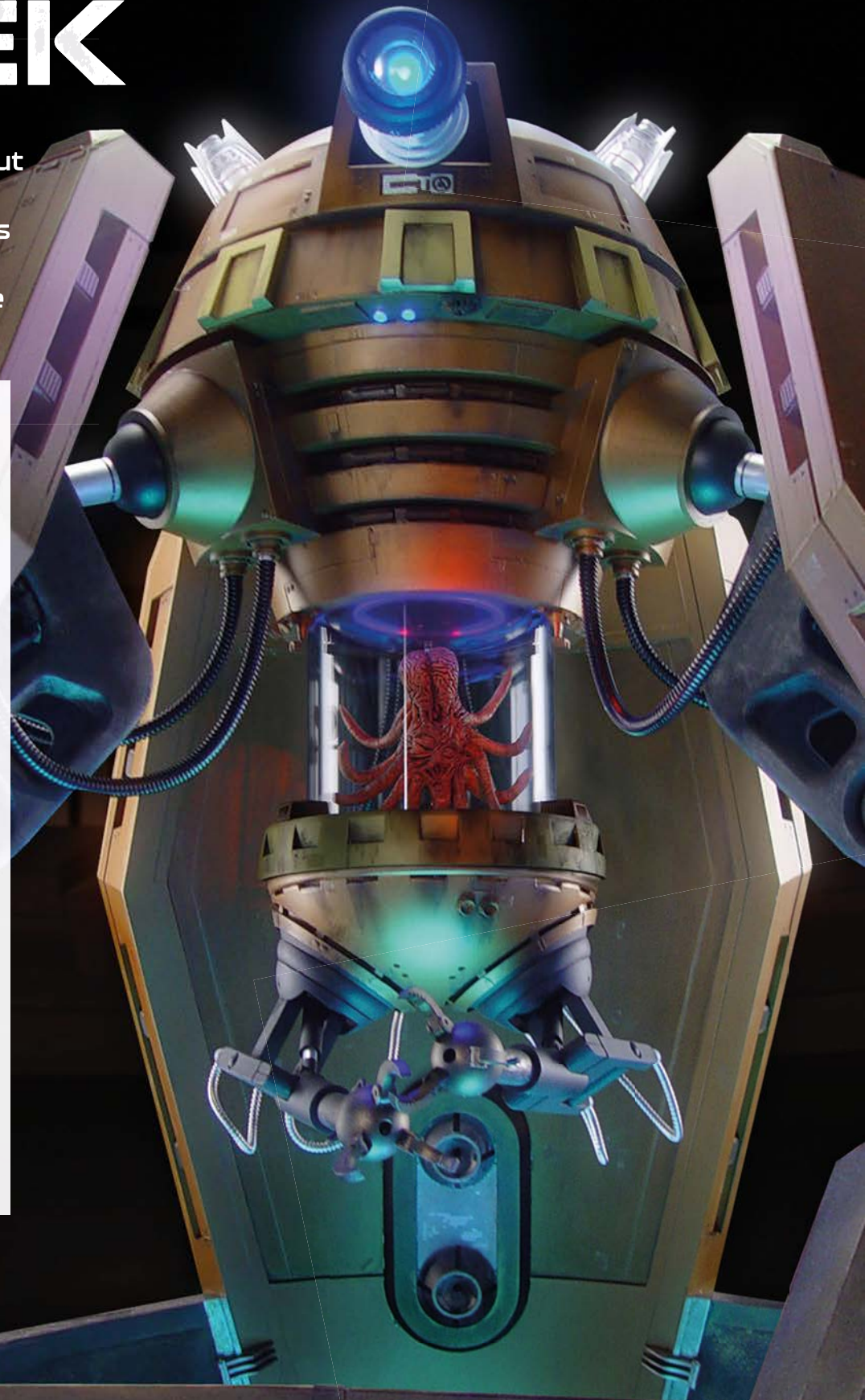

The three large panels that make up most of the Emperor's outer shell [2] are composed of pure Dalekanium, a hyper-dense alloy made from metals native to Skaro. It is ten times stronger than steel, yet has only the quarter of the weight of aluminium. The panels can withstand an explosive force of 300 megatons. The three panels can join together in an emergency, forming a sealed environment for the Emperor and giving it protection from an outside attack.

The domes that line the outer panels are mostly sensory units. They receive input from all areas of the Dalek fleet.

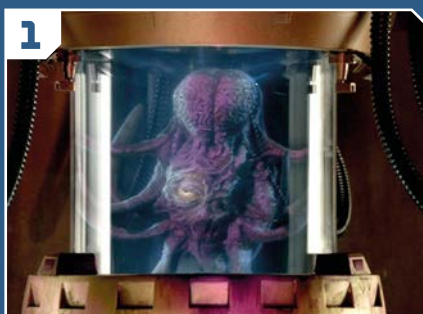

Each one contains a special processor that determines the strategic importance of the data being received and what priority it should be allocated. In this way, irrelevant information can be filtered out, leaving the Emperor to focus on more vital data.

There are two mechanical arms directly beneath the Emperor's tank [3], equipped with powerful claws to manipulate objects the Emperor wishes to study. The huge eye stalk has a much greater level of magnification than a normal Dalek's. It can perceive temporal radiation and energy waves from other dimensions.

The Emperor has the highest mental capacity of any Dalek ever created. It can make calculations at a similar rate to the most advanced computers and analyse information at the same speed. However, it chooses not to devote itself to such tasks, preferring to focus on creative strategy and propaganda.

The Emperor has a large proportion of the stored memories of the previous Emperors in Dalek history. The memories are encoded genetically and added to its DNA. This gives the Emperor the capacity to re-live key moments in Dalek campaigns and use the experiences of

its forebears when making judgments. Likewise, the Emperor's own memories are recorded and stored in a mnemonic processing bank situated above its tank [4], for possible future use by Emperors yet to be created.

The Time War made the Emperor privy to knowledge and experiences that went far beyond any of its predecessors. Despite being driven by hatred and xenophobia, Daleks are at heart a logical, methodical species, preferring routine and experience to guide their behaviour. The Time War forced them to change in a significant way. The Daleks found themselves in a conflict where standard causality was discarded completely. The Daleks' enemies could strike at them even after they had been destroyed, and the outcomes of battles could literally be reversed. The Time Lords and their allies manipulated time and space on a level that approached mysticism. The Daleks were used to warfare on a linear timeline, and were at first ill-prepared for the fourth-dimensional strategies of their opponents.



To counter this, the Emperor created the Cult of Skaro: a small, elite order of Daleks that were given a much greater imaginative capacity than a common Dalek. But the Emperor could also see the danger of one day being usurped by such a force, and chose to undergo genetic reprogramming on its own brain as well, giving itself the same imaginative advantages. It had no way of knowing that this action meant it had planted the seeds of its own destruction.

The siege of Gallifrey and the obliteration of the Dalek fleet that followed was a devastating time for the Emperor. The mothership was crippled. The Emperor ordered a retreat, and the ship plunged into a dark void beyond space and time. Few Daleks aboard survived. The Emperor faced the prospect that it would be responsible for the total extinction of the Dalek race.

Re-entering normal space, the Emperor stayed hidden near Earth, observing human society from afar. It watched the cruelties the human race inflicted upon itself, and how so many of them stemmed from warring religious factions. The concept of godhood had never been part of Dalek society, but the Emperor

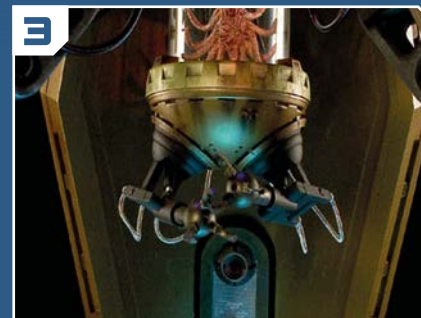

could see the advantages of leading a force that believed in a sacred destiny. It chose to model itself on the many gods of humanity. Its new race of Daleks was raised to believe that the Emperor was not simply the creator of the Daleks, but the creator of all existence.

And this was where the Emperor made its mistake. For as the centuries passed, and the number of Daleks worshipping it grew, it came to believe its own doctrine. Imagination always brings with it the possibility of insanity. The Emperor eventually became convinced that it was the god of all things. This belief in its own holy destiny led it into a conflict with another creature that also appeared to be a god: the Bad Wolf.

It is uncertain if the Emperor Dalek was completely obliterated by the Time Vortex energies wielded by the Bad Wolf or if it managed once more to escape annihilation. If it is the latter, it is doubtless hiding somewhere, planning its resurrection.

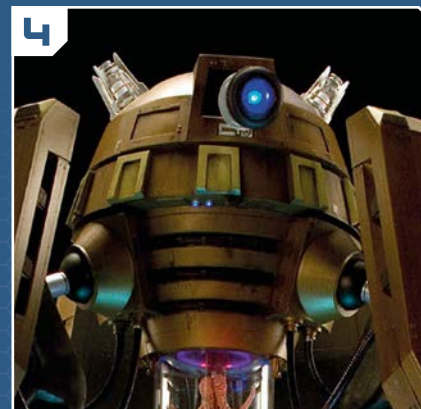

# MID SECTION

## DALEK MUTANT CONTROL CENTRE



### COMPONENTS OF ISSUE 18

- 18A** VIDEO CARD
- 18B** VIDEO BACK PANEL
- 18C** SUPPORT FOR BACKREST
- 18D** CENTRAL SUPPORT FOR VIDEO
- 18E** VIDEO CARD FRAME
- 18F** VIDEO SUPPORT (COLUMN 1)
- 18G** CONNECTING RINGS FOR VIDEO STAND
- 18H** VIDEO SUPPORT (COLUMN 2)
- EP** THREE 1.7 X 3MM PWB SCREWS (1 SPARE)
- AP** EIGHT 2.3 X 5MM PB SCREWS (1 SPARE)

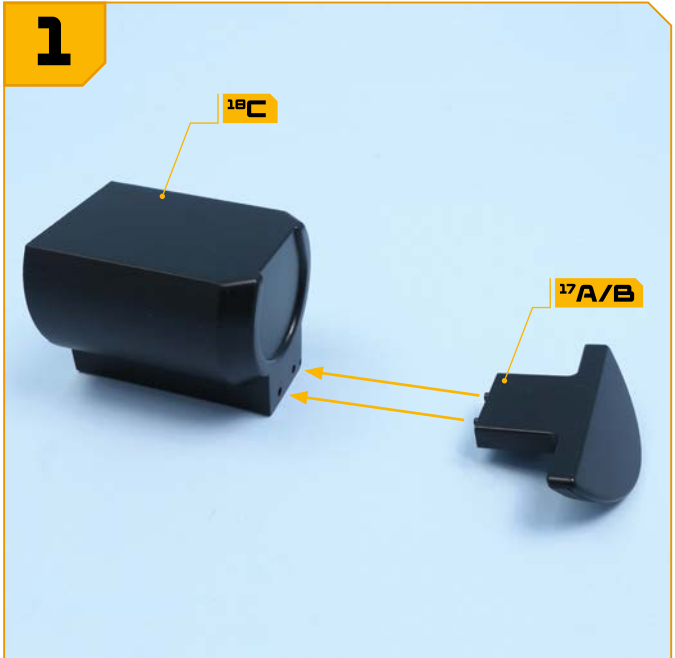

**#018-01**  
 Take the backrest assembly **17A** and **17B** from the previous issue. Fit the two small raised screw sockets in part **17B** into the two holes in the top of part **18C**.



**#018-02**  
 Fix the backrest in place with two EP screws (circled).

**TIP**  
 If you find it difficult to fit the screws, do a 'dry run', fitting the screws to part **17B** to cut a thread, and then take them out and complete step 2 as described here.

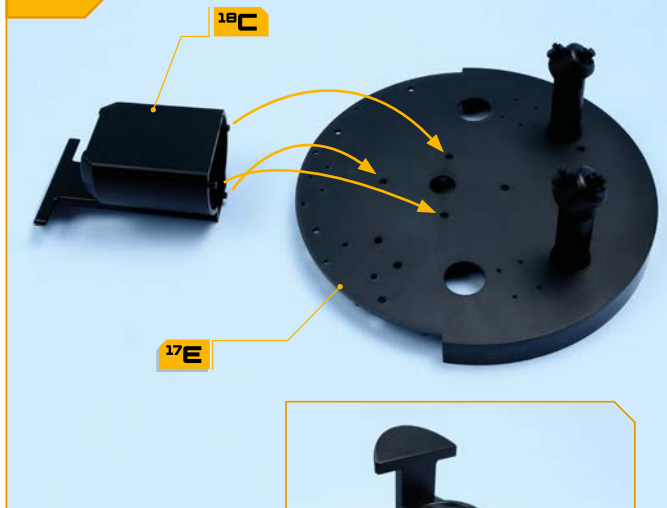

**3****#018-03**

Identify the fixing point for the backrest assembly in the centre of the base plate **17E**. Fit the raised screw sockets on the base of part **18C** into the holes in part **17E**.

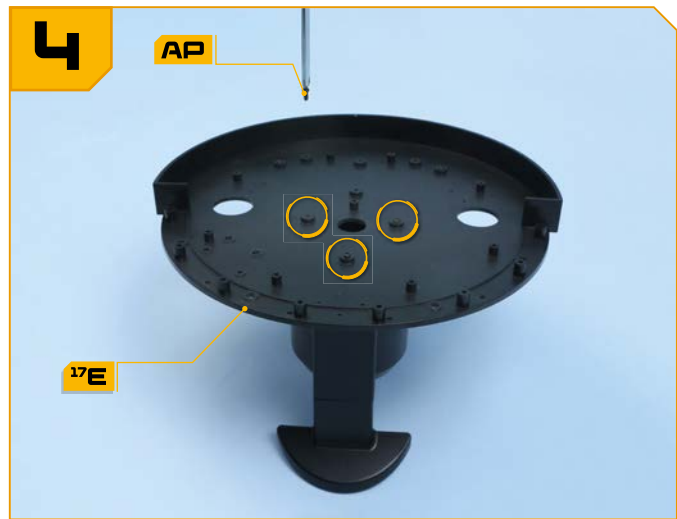
**4****#018-04**

Holding the backrest assembly in position, turn the base plate over so that you can fix it in place with three **AP** screws.

**5****#018-05**

Fit the back of the video back panel **18B** on to the video card frame **18E**. Six pegs on part **18E** fit into sockets on part **18B**.

**6****#018-06**

Take the video card frame **18E**, and check the orientation: the two screw sockets at the side (circled) should be nearer the top of the frame.



**#018-07**  
Fit the back of the video back panel **18B** on to the video card frame **18E**. Six pegs on part **18E** fit into sockets on part **18B**.



**#018-07**  
Stick the video card **18A** in place on the front of the frame **18E**.

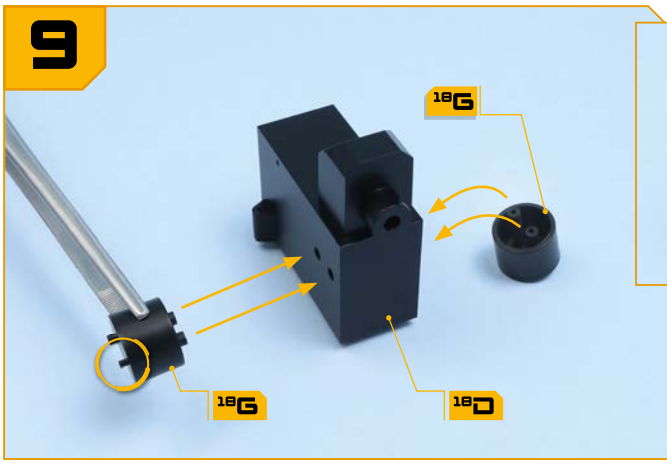

**#018-09**  
Take the two connecting rings **18G** and the video support **18D**. Fit one of the rings on each side of the support. Note that the rings have different sized pegs: the smaller peg (circled) should be next to the edge of the support. These are push-fit connections.

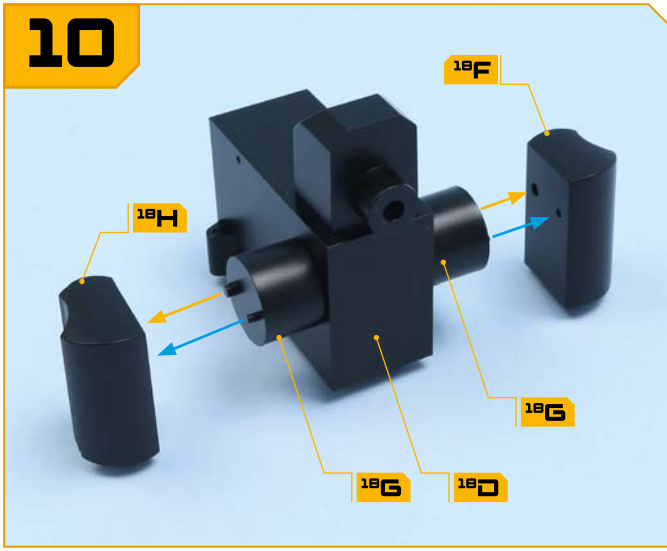

**#018-10**  
Take the two connecting rings **18G** and the video support **18D**. Fit one of the rings on each side of the support. Note that the rings have different sized pegs: the smaller peg (circled) should be next to the edge of the support. These are push-fit connections.



**#018-11**  
Fit the video stand assembly from step 9 on to the base assembly from step 3: the side supports **18F** and **18H** 'hug' the columns **17C** and **17D**; screw sockets on the base of parts **18H**, **18D** and **18F** align with screw holes in the base **17E** (circled).

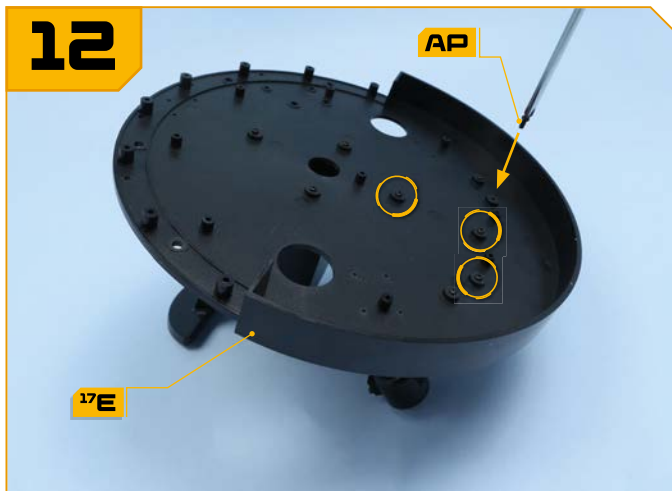

**#018-12**  
Turn the assembly over so that you can fix the video stand assembly in place with three **AP** screws.



**#018-13**  
Take the video card assembly from step 7 and check that it is the right way up, with the screw sockets on the sides of part **18B** (circled) near the top of the frame. Fit the pegs on the back of part **18B** into the holes in part **18D**, as indicated. This is a push-fit connection.



**#018-14**  
(Optional) The protective layer can be removed from the video card, but you may prefer to leave it in place while you build more of the model to keep the image protected.

#### COMPLETED WORK

##### #018-COMPLETED WORK

The control elements have been fitted to the base plate.



# THE DALEK

COMING IN  
ISSUE 19

## BUILD PART 19

The next issue brings you the alien to sit inside your Dalek – a fantastic piece to add to the build!



## THE TIME VORTEX



The Time Lord Victorious confronts the Daleks!

## ADVENTURES IN TIME AND SPACE



Discover the identity of the Prisoner of the Daleks.

Every week at your newsagent! Visit [hachettepartworks.com/Dalek](http://hachettepartworks.com/Dalek)