

# THE DALEK

**BUILD  
THE ICONIC  
BBC**



**MONSTER**



**DAVROS SEES  
THE FUTURE!**

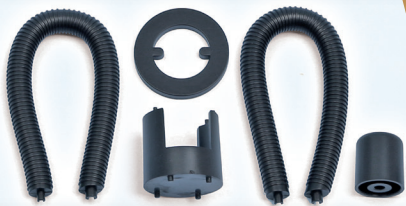

**STEP-BY-STEP  
INSTRUCTIONS!**

Published  
weekly • £11.99  
AUS • \$23.99

21 >



9 772977 557054

# DALEK

## ISSUE 21



### ADVENTURES IN TIME AND SPACE: DAY OF THE DALEKS – PART 3 **3**

On 22nd-century Earth, the Doctor is a prisoner of the Daleks.



### THE TIME VORTEX: DAVROS – PART 3 **6**

Davros learns the future of the Daleks from the Doctor.



### STEP-BY-STEP BUILD: PART 21 **8**

Pipes and the base which allow further construction of the neck area.

## Reader Services

CUSTOMER SERVICE IN THE UK  
AND REPUBLIC OF IRELAND

### How to continue your collection:

Subscribe online at [hachettepartworks.com/Dalek](http://hachettepartworks.com/Dalek) or contact the Customer Service team via [hachettepartworks.com/contact](http://hachettepartworks.com/contact)

### Customer service & back orders:

Please visit [hachettepartworks.com/contact](http://hachettepartworks.com/contact) to get in touch.

UK call 0345 155 9277

ROI call (01) 9079762

(Calls are charged at your local rate from a landline)

Published by Hachette Partworks Ltd  
4th Floor, Jordan House, 47 Brunswick Place, London N1 6EB

General Manager – Isabelle Couderc  
Editorial Director – Helen Nally  
Marketing Director – Elise Windmill  
Production Director – Sema Sant Anna  
Managing Editor – Sarah Gale  
Distribution Manager – Paul Smith  
Product Manager – Rhys Myner

Packaged by Panini Publishing, a division of Panini UK Limited.

Publishing Director Europe – Marco M. Lupoi  
Managing Director – Chris Clover  
Managing Editor – Alan O'Keefe  
Senior Editor – Ed Hammond  
Editor – John Ainsworth  
Designer – Barry Spiers  
Features Writer – Stuart Ashley

Distributed in the UK and Republic of Ireland by Marketforce.

© 2025 Hachette Partworks Ltd

Printed in the UK.

ISSN 2977-5574

ALL RIGHTS RESERVED

The editor's policy is to use papers that are natural, renewable and recyclable products and made from wood grown in sustainable forests. The logging and manufacturing processes are expected to conform to the environmental regulations of the country of origin.

In the event of a significant increase in production and transport costs, the publisher reserves the right to modify its selling prices.

BBC, DOCTOR WHO, TARDIS and DALEK (word marks and devices) are trade marks of the British Broadcasting Corporation and are used under licence. BBC logo © BBC 1996. DOCTOR WHO logo © BBC 1973. Dalek image © BBC/Terry Nation 1963. Licensed by BBC Studios.

The device complies with Part 15 of the FCC Rules. Operation is subject to the following two conditions: (1) this device may not cause harmful interference, and (2) this device must accept any interference received, including interference that may cause undesired operation.

All parts belong to a kit. NOT SUITABLE FOR CHILDREN UNDER THE AGE OF 14. This product is not a toy and is not intended for use in play. Follow the instructions in the enclosed magazines carefully and keep the appropriate information in a safe place. The installation of the electrical and electronic parts must always be carried out by an adult. Requires batteries.

BBC



For our environmental policy in full please scan the QR code here.

**hachette**  
PARTWORKS LTD

### WHAT TO DO WITH YOUR PACKAGING?

Our packaging papers and boxes are 100% recyclable kerbside. Plastic blisters can also be 100% recyclable kerbside once separated from the cardboard. To find out what you can recycle at home and locally, please visit [www.recyclenow.com](http://www.recyclenow.com)

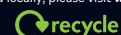

# DAY OF THE DALEKS

## PART THREE

In the 22nd century, the Doctor finds Earth under the brutal rule of the Daleks.

Season 9 Episode 3  
First Broadcast: 15 January 1972

Anat and Boaz make it back to the canal tunnel with the Doctor just behind them. He runs into the darkened tunnel and sees a swirling light forming in front of him. A Dalek appears inside it and yells, "Exterminate!" The Doctor runs for his life and finds Anat and Boaz in another tunnel. The Dalek discovers them as well. The two guerillas activate their time module and disappear, taking the Doctor with them. They arrive in the 22nd century. The Doctor wants to find Jo but Boaz isn't interested in helping. The Doctor and the guerillas separate when Ogrons and Daleks draw close. The Doctor reaches the surface and hides as a squad of Ogrons marches past him. He sees the world of the future, filled with crumbling buildings and vast stretches of wasteland.



The Controller reports to the Gold Dalek. He argues that the Ogrons are too stupid to combat the guerillas effectively. He requests more human guards but is denied. "Humans are treacherous and unreliable!" the Gold Dalek declares. When the Controller states that Jo mentioned someone called the "Doctor", and that he has now been sighted in their time period. The Daleks become agitated and demand that he be found and exterminated.



Before the Controller is allowed to depart, the Gold Dalek orders him to increase the target figures of the mines by ten percent. "But that's impossible!" the man protests: "If we push the workers any further, they will die!" The Daleks are uninterested. "Only the weak will die," one of them says. "Inefficient workers slow down production. Obey the Daleks!" The Controller sees that he has no hope of winning the argument. Another guerilla, Monia, moves across the wasteland and enters a ruined building. Descending some stairs, he hears the voices of Boaz and Anat. They



are arguing over their mission. Anat tells Monia that Sir Reginald Styles wasn't at the location they had been given. Monia tells them that Jo Grant is being held at the Controller's headquarters but the Doctor is still at large.

The Doctor makes his way to a factory, unaware that he has been spotted by a security camera. He enters the factory and watches some human slaves at work. They are exhausted, dressed in rags. They are pouring rocks into funnels. The Doctor is seen by two guards. He tries to escape but is discovered by an Ogron and knocked unconscious.

Jo and the Controller enjoy a meal together. Jo asks if she can be returned to her own time in the 20th century but the Controller says that it is a difficult task for his scientists. He then gives her news of the Doctor: "He has been seen in our time zone with the criminals who attacked you. Doubtless they kidnapped him." Jo wants to help find him, but the Controller refuses. "You have to stay here for your own safety," he says. "If those criminals saw you here, they might think you'd betrayed them, and in any case, they would try and harm you." Jo looks at the brutish guard standing at the door to her chamber. The Controller assures her that he is only there to protect her. A message is brought to the Controller. He smiles at Jo, and tells her the Doctor has been found and is well... In fact he has been beaten by the guards. He is dragged to a cell in the factory for interrogation and accused of being a spy. The factory's manager arrives and orders the interrogator and the Ogrons out of the



cell. Once they are alone, the manager leans in and whispers, "Which group are you from?" to the Doctor. "We haven't much time, who sent you?" the man asks. The Doctor denies being any kind of spy. The cell door rises and the Controller enters. The manager quickly switches back to a harsh tone and starts barking accusations at the Doctor.

The Controller affects a pleasant manner. "My dear Doctor, I cannot apologise enough!" he says. The Doctor struggles to rise, unsure of the man's motives. "You are an honoured guest of our government," the Controller says, smiling. He claims that the Ogrons' attack was all a misunderstanding. The Controller tells him that Jo Grant is waiting for him at the



## SCOTT FREDERICKS



Scott Fredericks played Boaz. "I had a lot of scenes with Anna Barry [Anat] and Jimmy Winston [Shura]," he recalled. "We were a kind of trio of freedom fighters against the Daleks. There was no great subtlety but it was amazing

fun. Very much a 'Cowboys and Indians' kind of script. Aubrey Woods had the best part as the Controller. I had worked with him before, and he's absolutely marvellous. A very Dickensian actor, dead right for the part." Fredericks returned to *Doctor Who* in 1977 to play Max Stael in the Fourth Doctor story *The Image of the Fendahl*.

## DYSTOPIA



Writer Louis Marks described the dystopian future Earth in his rehearsal scripts: 'A desert of rubble and ruin. A feeling of war on an HG Wellsian scale which... razed every building to the ground... Neglected, crumbled, almost vanished... [The Doctor] pokes at the remains of a crumbled wall. It collapses into a small pile of dust. It

puzzles him.' Scenes of the future Earth were augmented in the 2011 DVD release of the story, with additional buildings rendered with computer graphics (pictured here).



Control Centre. The Doctor leaves with a guard, but not before the manager gives him a subtle shake of his head, alerting him to the danger that lies ahead.

The Controller tells the manager that production in his factory must increase by ten percent. When the manager protests, the Controller threatens the man's family. After the Controller leaves, the manager contacts Anat and Monia and tells them about the Doctor. Before he can give them more information, he is clubbed to the ground by an Ogron.

The Controller hosts dinner for the Doctor and Jo. The Doctor is unconvinced by the Controller's claims that people on Earth are happy and prosperous. The



Doctor challenges him about the mining factory he saw, with people being forced to work there. The Controller insists that the factory is a rehabilitation centre for criminals. The Doctor points out that any regime that needs to import savage aliens to act as enforcers is an unjust one. "Who really rules this planet of yours?" the Doctor asks him. The Controller is unwilling to answer and leaves.

Jo is upset by the Doctor's attitude. The Doctor sees that Jo has been taken in by the Controller's pretence. "That man is no more than a superior slave himself. Humans don't rule this world any longer, Jo." When Jo asks who does, the Doctor responds with deadly seriousness. "The most evil, ruthless life-form in the cosmos. The Daleks."

The Controller is with the Daleks, watching the Doctor and Jo on a monitor. He is surprised to hear from his masters that this Doctor has a different appearance to the one they know. The Daleks say that they will determine his identity with their mind analysis machine.

Jo starts screaming to lure their Ogron guard into their room. The Doctor fights the Ogron but it is Jo who defeats the large creature by hitting him on the head with the wine bottle. They escape outside and find a three-wheeled motorised bike. The Doctor and Jo try to escape into the wasteland but are soon captured by more Ogrons.

Monia tells Anat and Boaz that he has received new information on the Doctor. "He is the sworn enemy of the Daleks,"



he says. "He's the one man they're afraid of." Monia insists that they mount a rescue attempt to save the Doctor.

The Doctor is strapped to a table and subjected to the Daleks' mind analysis machine. He lies helpless as images of his two former selves are projected onto a screen. "You are the Doctor!" the Gold Dalek cries. "You are an enemy of the Daleks! Now you are in our power, you will be exterminated!" The other Daleks join in the chant: "Exterminated! Exterminated! Exterminated!"



## MONSTER MASKS

Visual effects designer John Friedlander created the impressive Ogron masks: "They contacted me and said they needed all these monsters in the studio at once – about 12, I think – and the director [Paul Bernard] had expected the [make-up staff] to make up 12 actors the next morning. It would have taken hours using separate make-up pieces. So, I said, 'Why can't you use a mask?'" Friedlander constructed a generic Ogron mask that ended at the upper lip, meaning that only the eyes and mouth area would need make-up. "In actual fact, some of the Ogron actors were such big men – really enormous – that the masks didn't fit. I've still got some slides of them and without make-up, you can see that the lip is right over and it's cutting in because their heads were so broad. We had to split them and stick pieces in just to make them fit."



# DAVROS

## PART 3



In the final days of the Kaled-Thal war, Davros was working harder than ever before. The Mark 3 travel machines he had designed for his Kaled mutants were reaching a critical stage.

The armour that Davros had built for the Daleks, the weaponry, the visual sensor, the mobility factor – all these challenges had been overcome.

The Kaled mutants themselves were also occupying much of his time. Their forced evolution had reached a critical tipping point. Davros wanted them to develop, not just a resistance to radiation and other forms of toxicity, but the ability to actually thrive on such poisons. It was a delicate procedure that had resulted in the deaths of thousands of mutant embryos, but he had at last produced a batch that could survive any type of pollution. Just as importantly, their psychological state had been successfully manipulated at last. The mutants'

only motivations were total obedience, a burning hatred of all other lifeforms, and an absolute belief in their own superiority. They were the perfect species, one untouched by such distractions as love, compassion and individuality.

These challenges were of Davros' own making, of course, and he relished them. But there were also administrative obstacles littering his path. An endless line of politicians, soldiers and civil servants from the Kaled dome were demanding his attention with requests for meetings, investigations, reports and other trivialities. He despised them all.

Another problem had unexpectedly developed, coming from his own hand-picked Scientific Elite. All of them possessed great intellects but, as the goal of the Dalek Project became clearer to them, their absurd sense of morality had turned some of them against him.

With so many difficulties to overcome in such a short span of time, Davros found himself being pulled in many different directions. As a result, he failed to identify the single greatest threat to his life's work: a scruffy, unassuming individual known only as the Doctor.

Davros had focused his life on the war and the survival of his people, and had given little thought to the wider universe beyond Skaro. The possibility of being visited by intelligent alien life seemed hopelessly unlikely to him, and he had dismissed it. But one look at the analysis report of the Doctor's biology altered his view instantly. The Doctor was clearly from a civilisation far more advanced than his own, one, he soon learned, that could travel in time as well as space.

Davros learned from the Doctor that his creations would survive and thrive in the future. His spirit soared when he was told that they were regarded with fear across the known universe. He had planned for the Daleks to be the rulers of Skaro; now, he knew that their empire would be infinitely greater. But that was not enough for him, even a single Dalek defeat was one too many. With a time-traveller in his clutches, Davros understood that history itself could be outwitted.

At first the Doctor refused to give Davros any details of the Daleks' wartime failures, but he proved an easy interrogation subject – after his companions had been subjected to a few seconds of piercing pain directed at their central nervous systems, he relented. The Doctor spoke for hours. Davros listened intently to every word. There would be Dalek defeats on



The Doctor turns the tables on Davros.

hundreds of worlds he had never heard of, in galaxies he never dreamed existed. As powerful and cunning as he had made his creations, they would still need his guidance to become the supreme rulers of the cosmos.

Davros was intrigued by the Doctor and his experiences far beyond his own. He called the Daleks 'evil' which Davros knew was a crude simplification. His Daleks were conditioned to survive, and Skaro was clearly only a microcosm of the greater universe. They would have to go on being warriors for ever. They had a higher purpose the Doctor did not understand, they would bring ultimate peace through total dominance.

The Doctor asked Davros a question: "Davros, if you had created a virus in your laboratory... something contagious and infectious that killed on contact... a virus that would destroy all other forms of life... would you allow its use?"

Davros found the conjecture exhilarating. To hold such power in his hand would be the ultimate achievement of any scientist. He would be above the gods themselves! But Davros suddenly felt the Doctor's strong hand around his aged wrist, and he knew he had been tricked. The Doctor had deduced which switch would shut down his life-support system. He activated it and, for a moment, Davros was hurled into an eternal darkness. When he was revived, he felt not only a burning rage, but also humiliation. He was now at the mercy of an alien, and it was his own fault. The Doctor demanded that he give the order to destroy the Dalek incubation chamber. Davros was about to comply, but then Nyder was suddenly there, the only man he had ever truly trusted. Nyder subdued the Doctor and Davros was saved, and so were his Daleks.

One last barrier to total victory still remained, however: Gharman and the other elite scientists and soldiers who were opposing the Dalek project. The Doctor and his companions were soon freed, and Davros found himself yet again facing a group of spineless individuals who spoke of 'democracy' and 'conscience'. Only two of his scientists moved to stand with him. Gharman and the others were traitors, not just to Davros but to the Kaled people. They had lost the privilege of life. Davros enjoyed the looks of fear on their faces as his Daleks glided into the room. Gharman and the others screamed as they died.

The long battle was over, Davros thought. All the struggles had been worth it. The automated Dalek production line was ready to be activated. His creations' destiny was safe.

A sound alerted Davros. He turned to see that the production line had begun. He demanded to know who had given the order. "I gave the command," a Dalek

replied. Davros turned to it. "You will obey only my commands," he declared, and ordered it to switch off the production line. The creature simply stared silently at Davros. "Obey!" Davros shouted. Again, nothing but silence. Davros gave Nyder the order instead. Nyder moved to the controls and was swiftly cut down by a Dalek blast. He fell to the floor, dead.

Davros suddenly felt as if the world had turned upside-down. His Daleks, his creations, his children – were now surrounding him. He realised that he had done his work too well. The Daleks had been programmed to see themselves as creatures superior to all other life. They would allow nobody else to command them – not even him. The Daleks aimed their weapons at the few men who had been loyal to Davros. "Have pity!" Davros yelled. A Dalek replied that it did not understand the word. The men joined Nyder in death.

There was a self-destruct switch for the Dalek production line. Davros turned and, almost by reflex alone, reached out to it with his gnarled hand. He could never suffer betrayal, not even from the Daleks themselves. The words on the switch – 'TOTAL DESTRUCT' – were the last thing Davros saw before oblivion took him. He screamed as the Daleks' blasts hit him, and then lay still in his chair. The Daleks' sensors registered him as dead. He was of no further interest to them.

But Davros was a survivor. He had overcome starvation, plague and war. He and death were old adversaries, and he had devised many ways to cheat it...

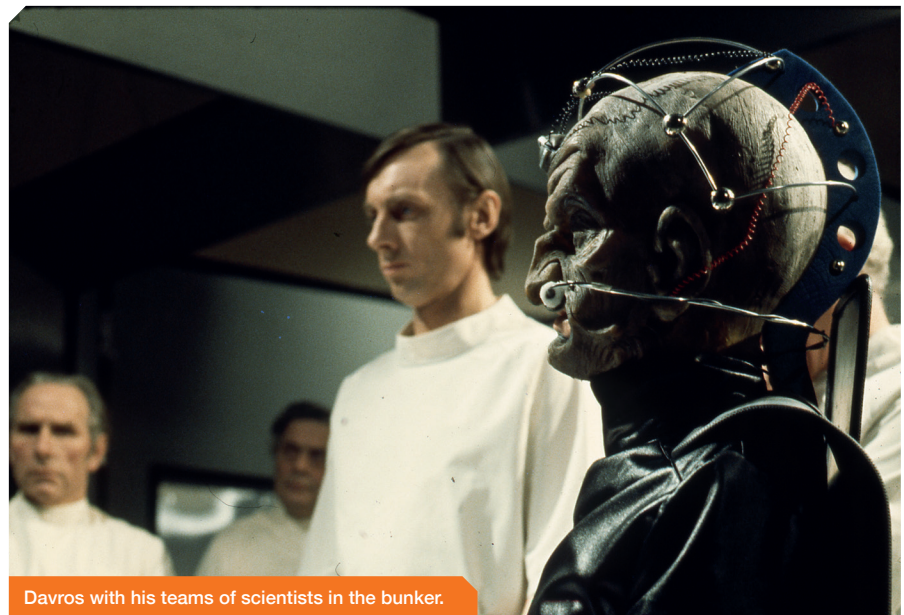

Davros with his teams of scientists in the bunker.

# MID SECTION

DALEK MUTANT CONTROL CENTRE



21A



21B

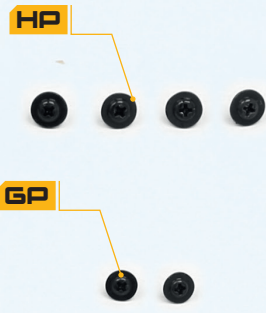

HP

GP



21C



21D



21E

## COMPONENTS OF ISSUE 21

21A PIPEWORK

21D CYLINDRICAL ATTACHMENT (INTERIOR)

HP 2.6 X 6MM PWB SCREWS (1 SPARE)

21B PIPEWORK

21E CYLINDRICAL ATTACHMENT (BASE)

GP TWO 2.3 X 4MM PWB SCREWS (1 SPARE)

21C CYLINDRICAL ATTACHMENT (TOP)

—

—



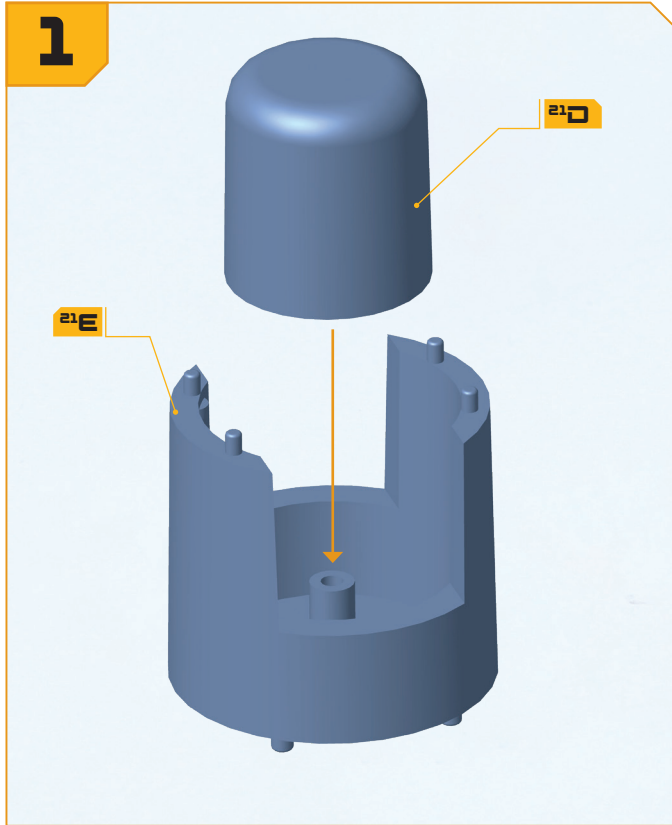

**#021-01**  
Take the interior **21D** and base **21E** of the cylindrical attachment. Fit the interior centrally on the base. This is a push-fit connection.

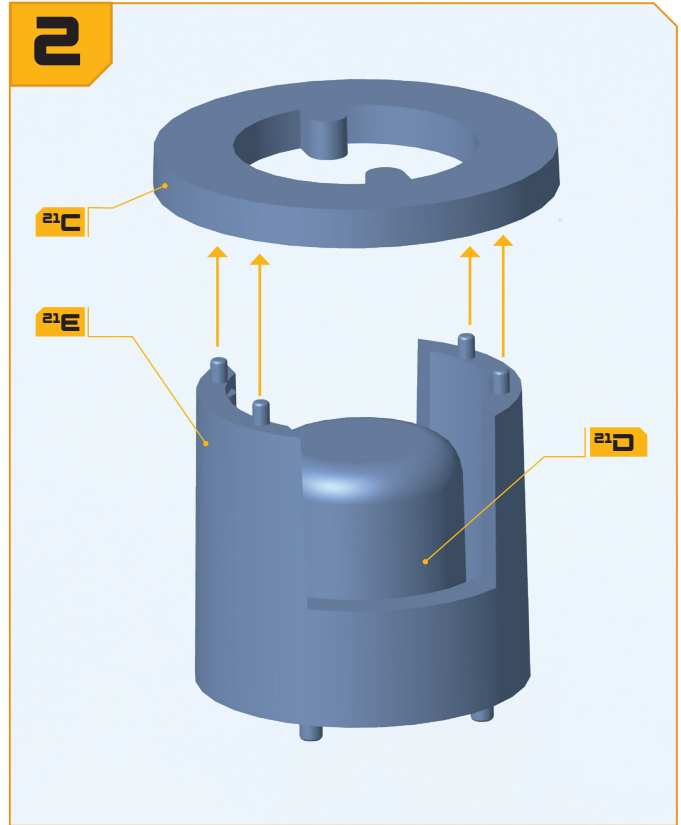

**#021-02**  
Fit the top **21C** on to the base: four pegs on the top of part **21E** fit into sockets in part **21C**. To ensure the correct orientation, the spacing of the pegs is different on each side. This is a push-fit connection.

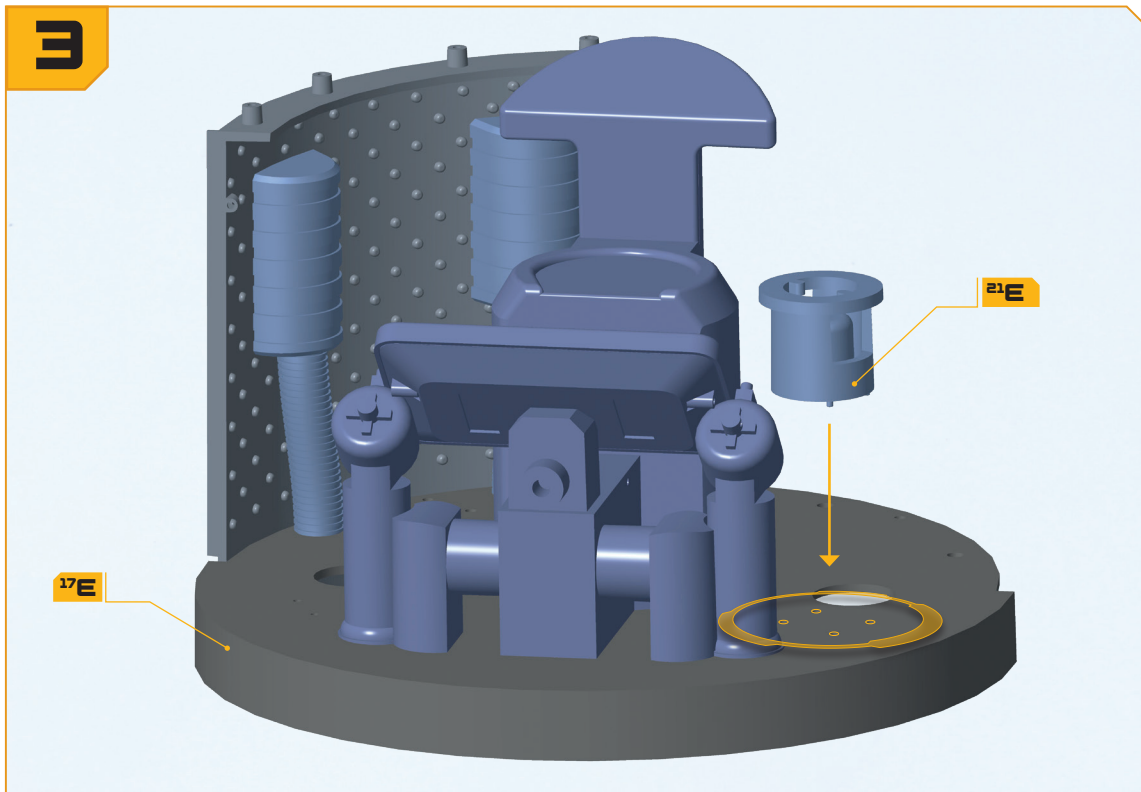

**#021-03**  
Fit the cylindrical attachment **21C/21D/21E** on to the base **17E**. Four small pegs on the base of part **21E** fit into holes highlighted in yellow (circled). The holes are unevenly spaced so that the attachment is fitted in the correct orientation. This is a push-fit connection.

4

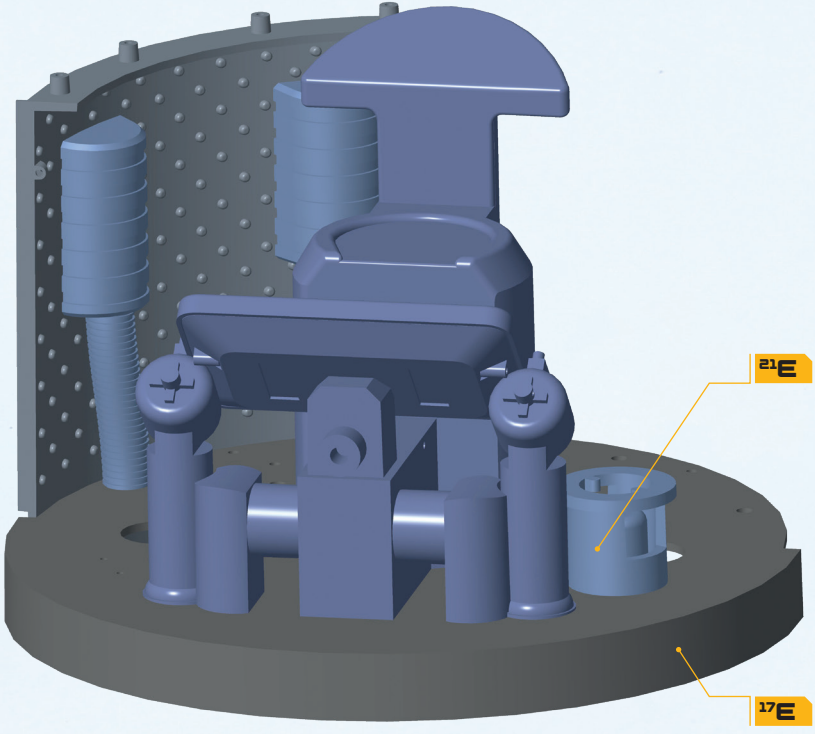

#021-04

This diagram shows the cylindrical attachment in position.

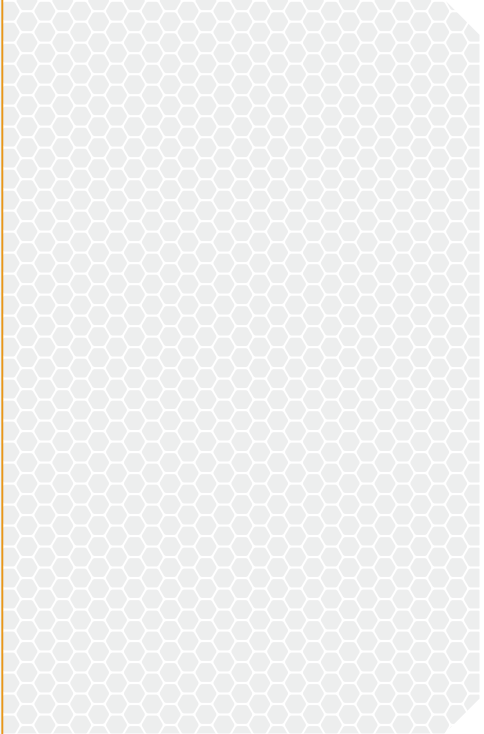

#021-05

Take the pipework 21A. Note that the ends of the pipework on this part are wider apart than the ends of the pipework part 21B. Fit the peg on the ends of the pipework into the holes highlighted in yellow in part 17E. See also step 6, which shows part 21B in place. One peg is larger than the other, to help you fit the pipework in the correct orientation.

Turn the assembly over so that you can fix part 21A in place with a GP and an HP screw, as indicated.

5

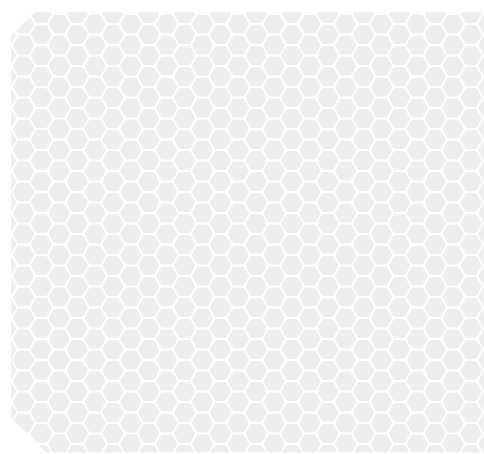
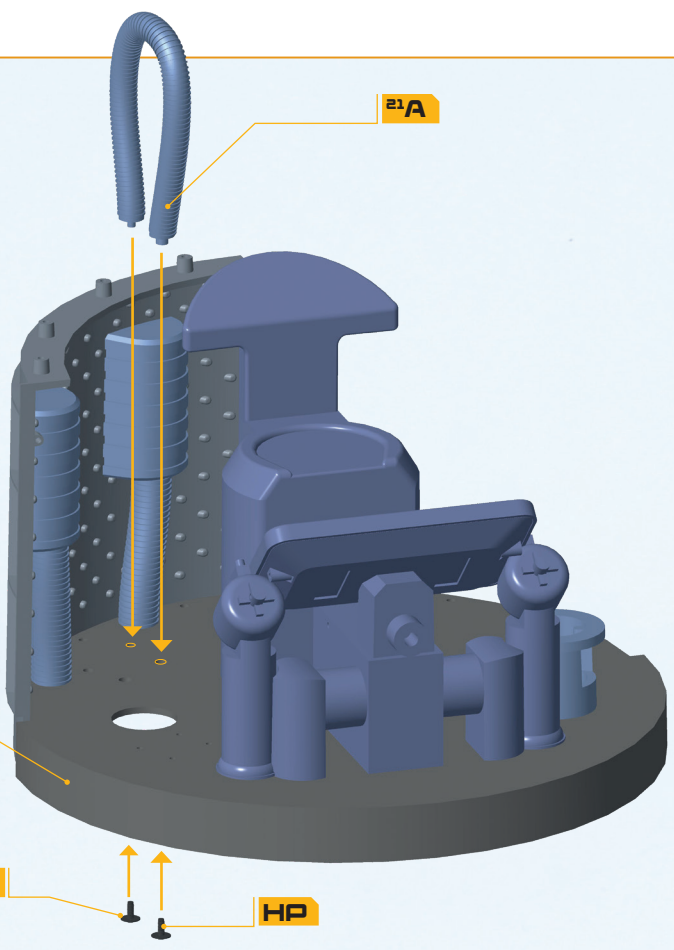

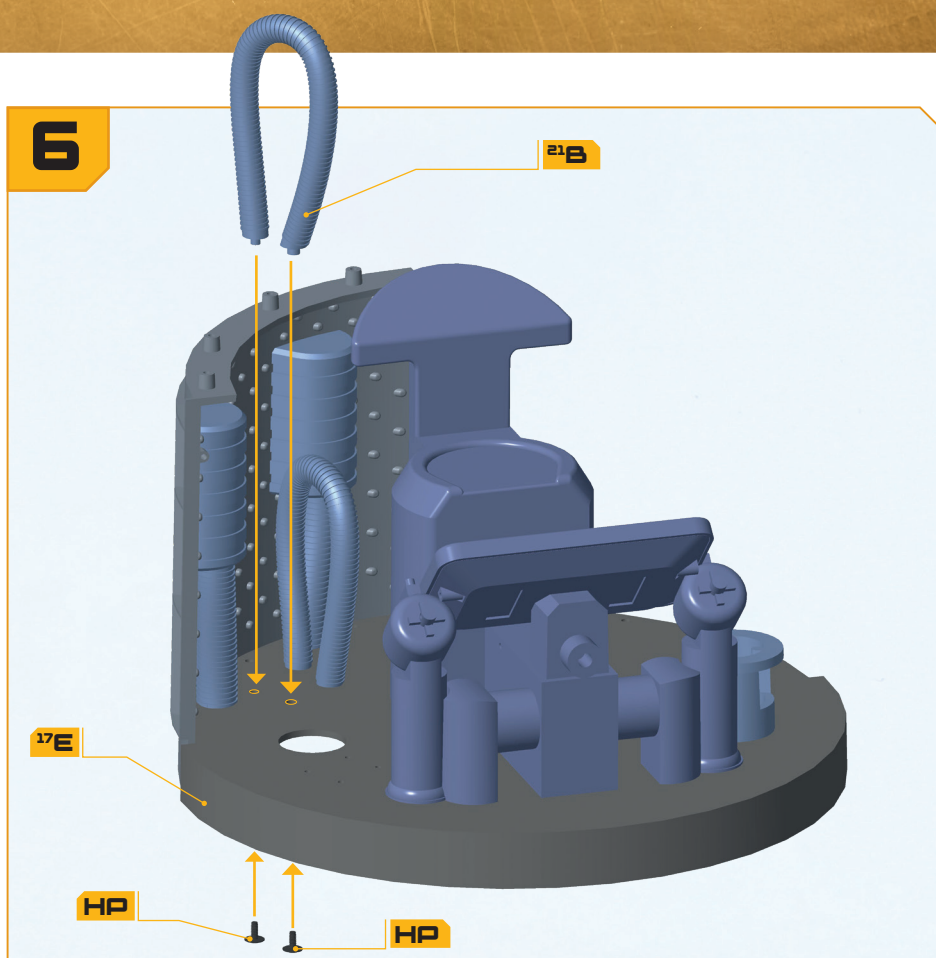
**6****#021-06**

Fit the second pipework **21B** (with a smaller gap between the ends of the pipe) into the base **17E**. Again, one peg on the end of part **21B** is larger than the other.

Turn the assembly over so that you can fix part **21B** in place with two **HP** screws, as indicated.

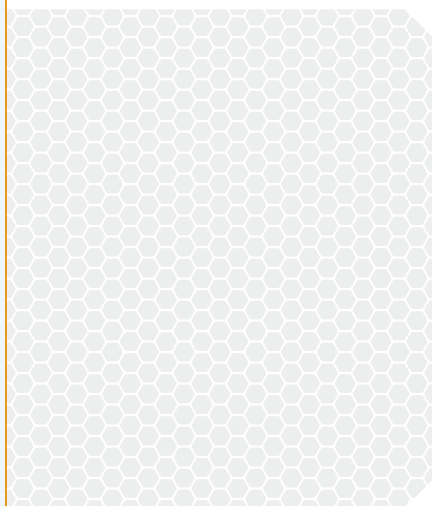
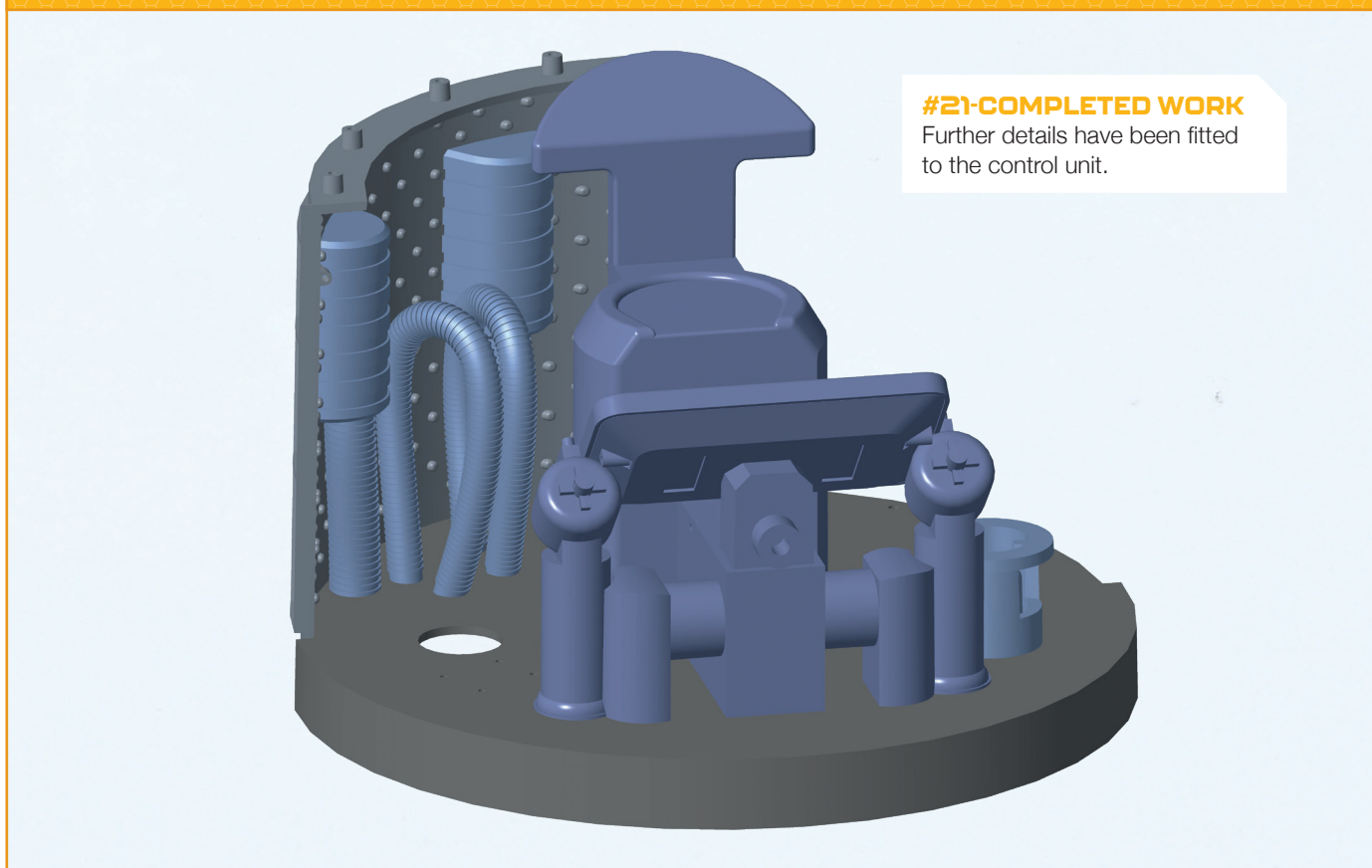
**COMPLETED WORK****#21-COMPLETED WORK**

Further details have been fitted to the control unit.

# THE DALEK

COMING IN  
ISSUE 22

## BUILD PART 22

Two further bucket pieces, two pipe attachments and the fixing base, along with its cover section and screws to continue to build within the mid-section.



## THE TIME VORTEX



The Seventh Doctor battles across time with the Daleks!

## ADVENTURES IN TIME AND SPACE

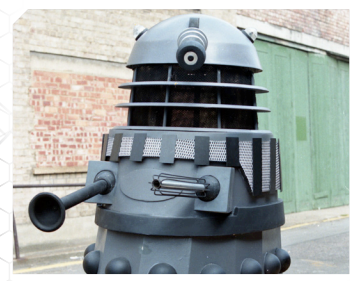

Discover the Hand of Omega in *Remembrance of the Daleks* – 3.

Every week at your newsagent! Visit [hachettepartworks.com/Dalek](http://hachettepartworks.com/Dalek)